

INTIEL

THE ELECTRONICS ON YOUR SIDE

Electronic Level Controller

User's manual



tel.: 0596.333.66 ||| fax: 0596.325.80 ||| info@intiel.com ||| www.intiel.com.

10 Major Kolontaevski Str, Pomorie 8200, Bulgaria

I. Application

The Electronic Level Controller is designed to keep a fixed level of water or water solutions in reservoirs.

II. Operation

The Controller is designed to keep the level of the regulated volume by means of a probe. During reservoir filling up the light indication 1(red) appears and the Regulator follows the sensor for the upper level. The relay contacts connect to terminals 6 and 7 (Figure 2). When the regulated level reaches the upper level sensor, the red indication 1 stops and the green indication 2 appears (Figure 1). The indication 2 signalizes for drawing off the reservoir contents and following of the lower level sensor. The relay contacts connect terminals 5 and 6 (Figure 2). When the fluid level reaches the lower level sensor, the indication 2 stops and the light indication 1 appears. The filling regime will be repeated.

Maximal length of the wires from controller to measuring probe is 30 meters.

III. Technical data

- Power supply:	220V/50Hz/AC
- Nominal current through the contacts:	10A/250V
- Number of contacts:	one switching
- Regulation precision:	10 mm
- Breakthrough voltage between the contacts:	1000V
- Length of the probe L(mm):	150,200,250,300,350,400

IV. Wiring diagram



Figure 1

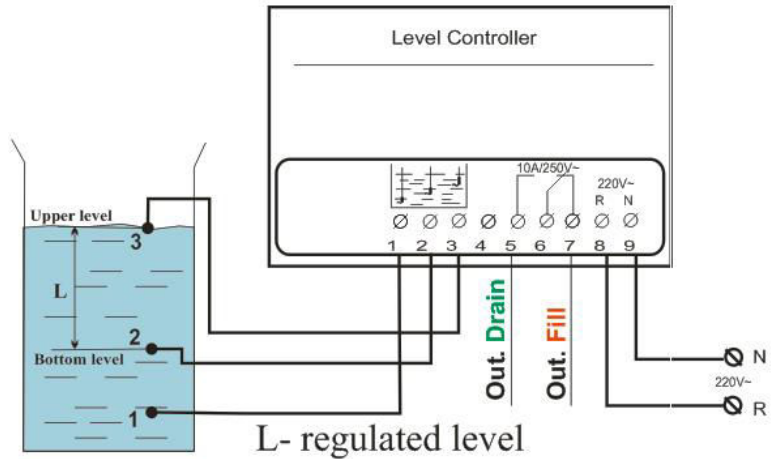

Figure 2

V. Warranty

The warranty period is 24 months following the purchase date of the unit or its installation by an authorized Engineering Company, but not exceeding 28 months after the production date. The warranty is extended to the malfunctions that occur during the warranty period and are result of the production reasons or defective used parts. The warranty does not relate to malfunctions corresponding to not-qualified installation, activities directed to the product body interference, not regular storage or transport.

The repairs during the warranty period can be done after correct filling of the manufacturer warranty card

Warranty Card

Manufacturer: INTIEL	
Product type:	<i>Level Controller</i>
Production number:	
Production date:	
Dealer's confirmation	
Purchase date:	
Invoice number:	
Dealer's name, address and stamp:	
Seller's name and signature:	
Installation date	
Date:	
Company (address, stamp):	

tel: 0596.333.66 ||| fax: 0596.325.80 ||| info@intiel.com ||| www.intiel.com.
10 Major Kolontaeovski Str, Pomorie 8200, Bulgaria